

# BUDGET BABY

NON SEXUALLY TRANSMITTED CHILDREN  
BY CALL ME FRANK

NO CRYING! NO FEEDING! NO CHANGING! NO BATTERIES! NO USE!



HEAD

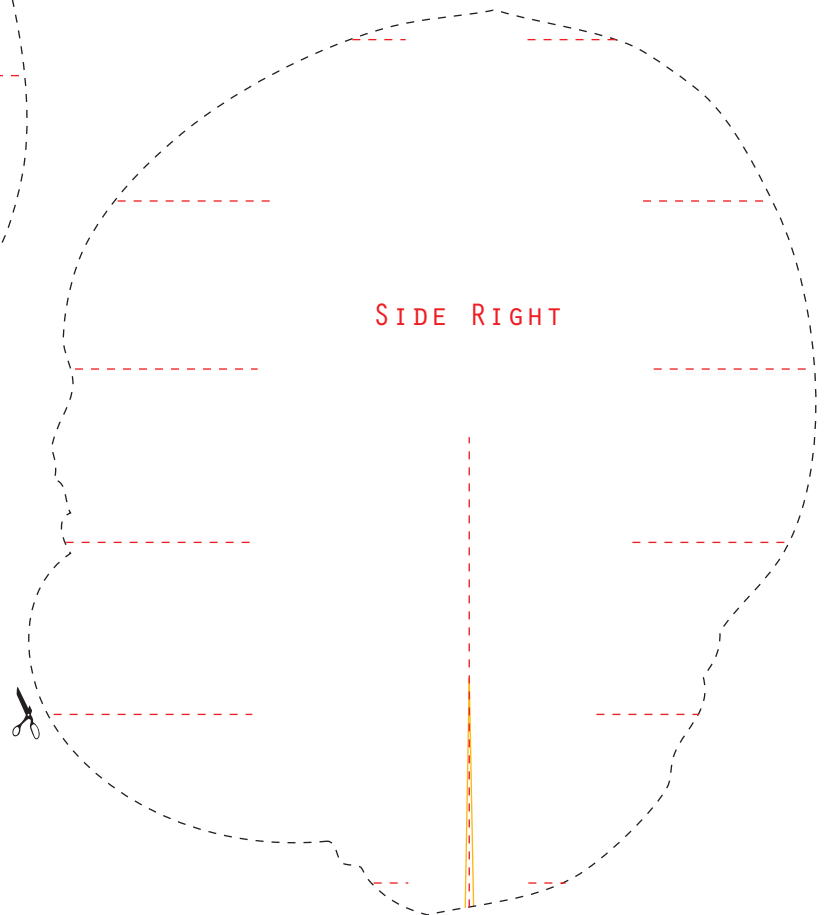
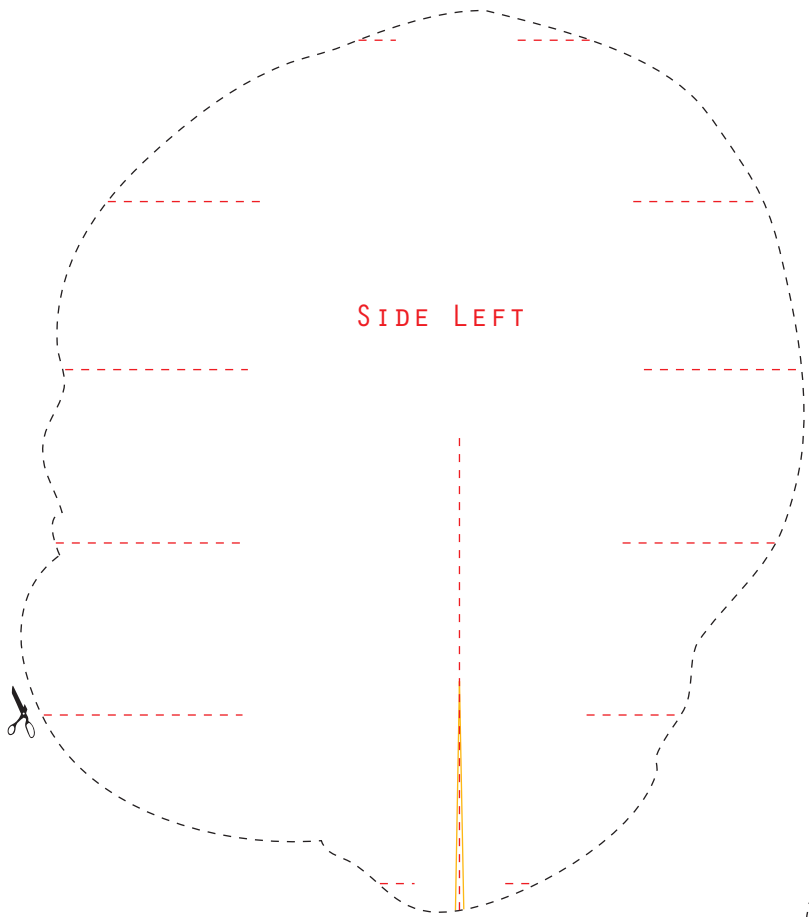
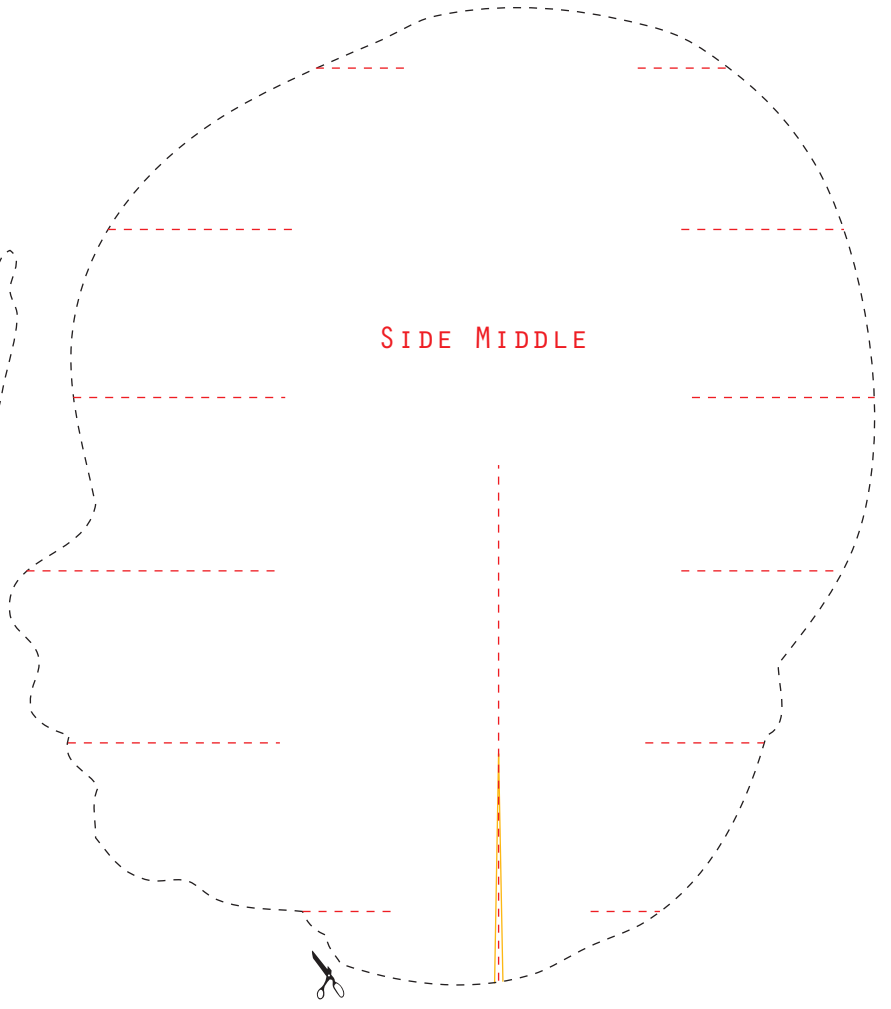
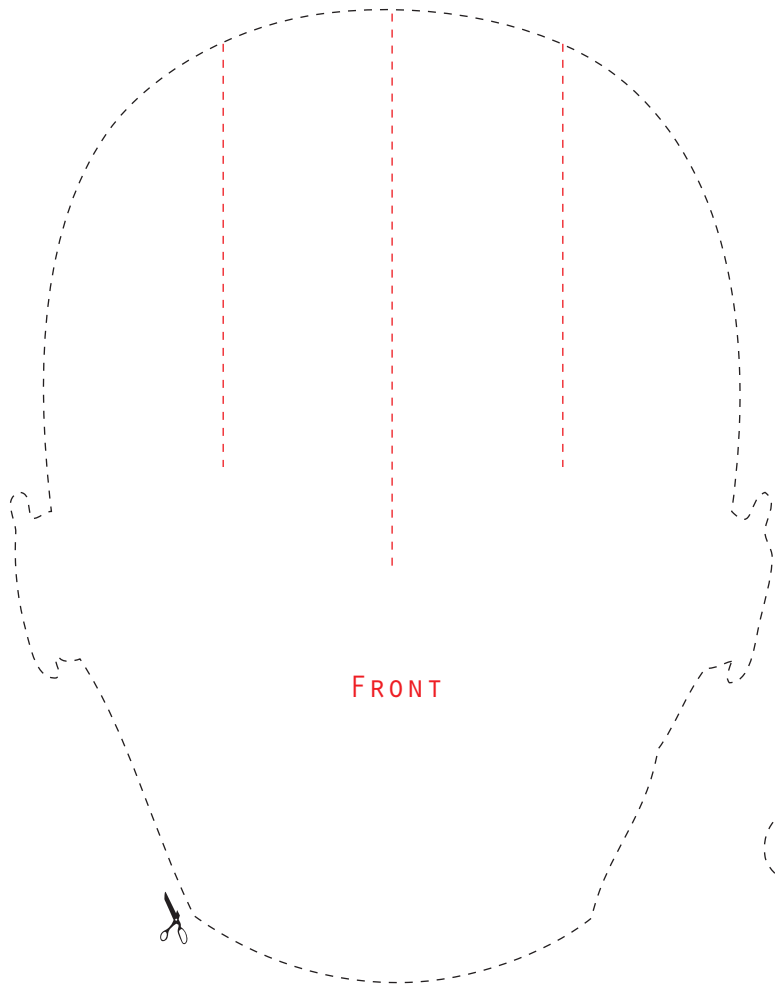

- CUT OUT
- - - MAKE INCISION
- WIDEN IF NESCECARY



# HEAD

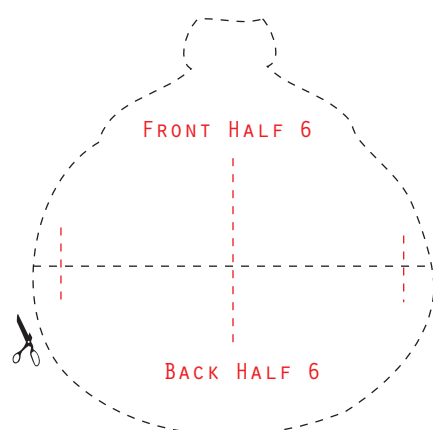
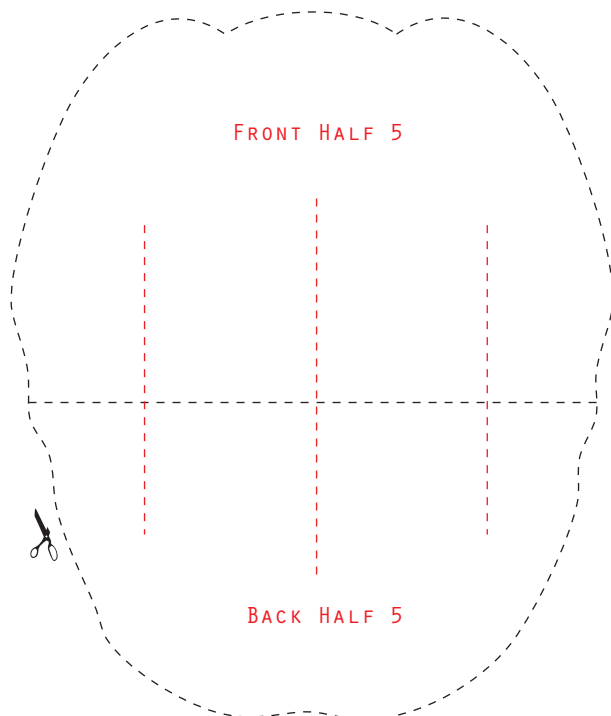
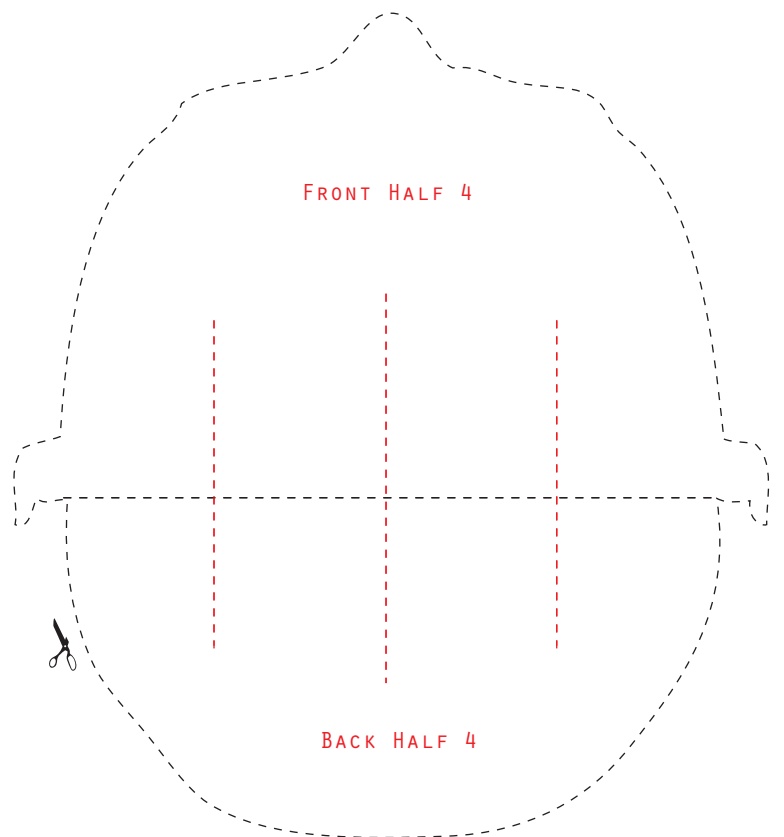
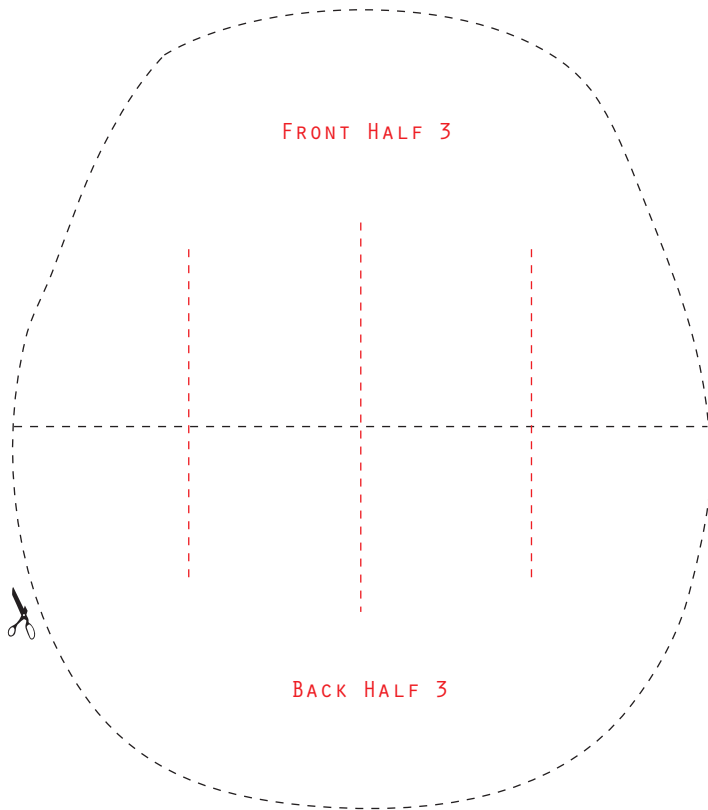
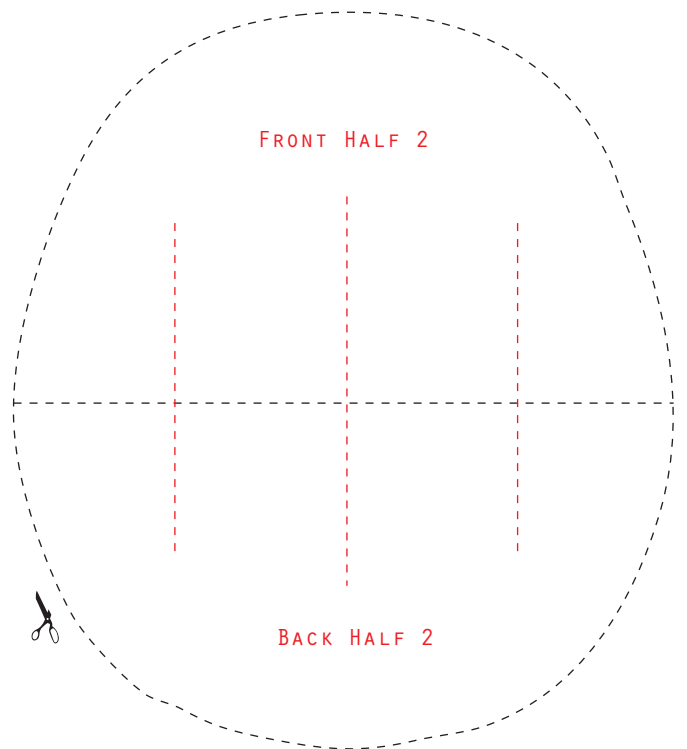
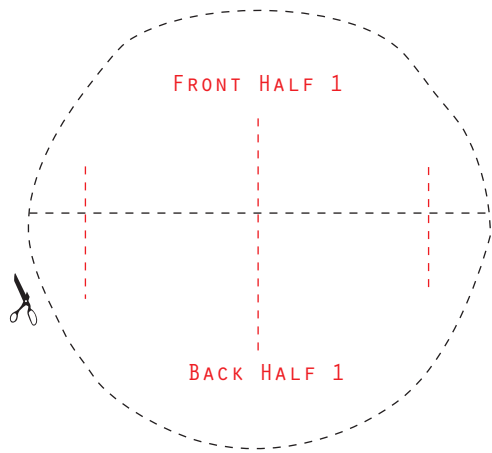

- CUT OUT
- - - MAKE INCISION
- WIDEN IF NESCECARY

HEAD ASSEMBLED

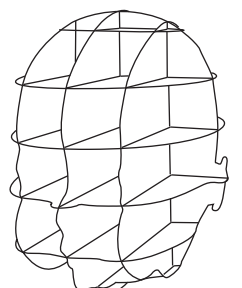

TORSO

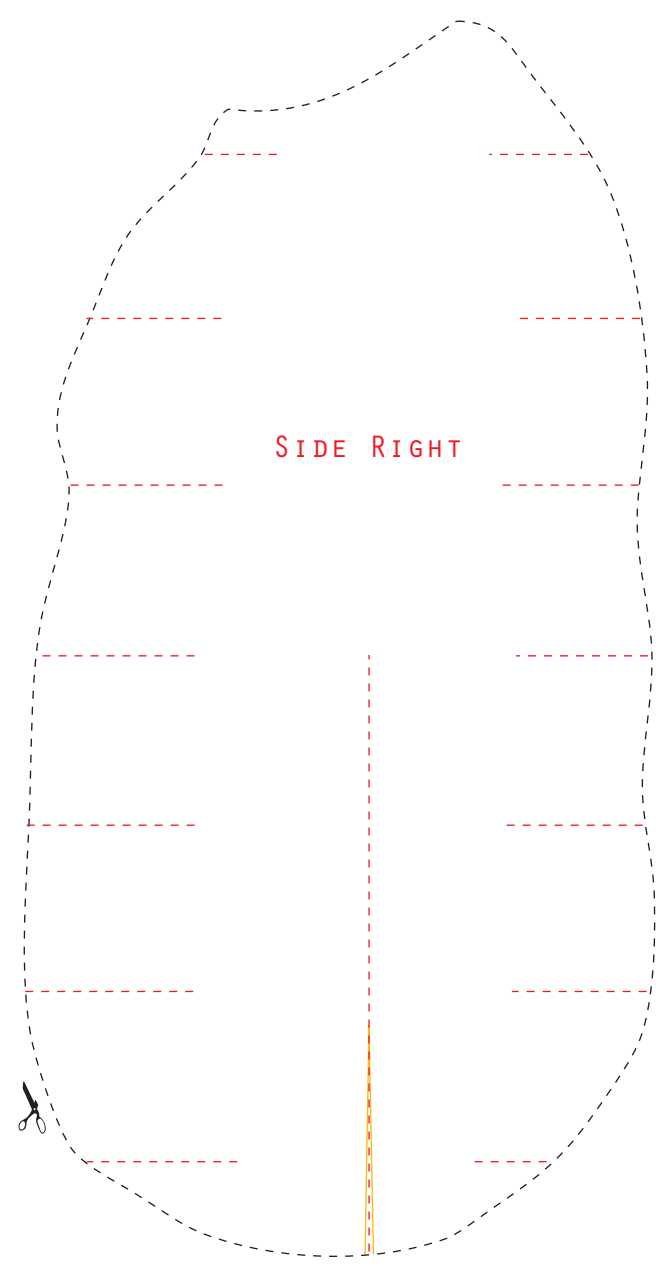
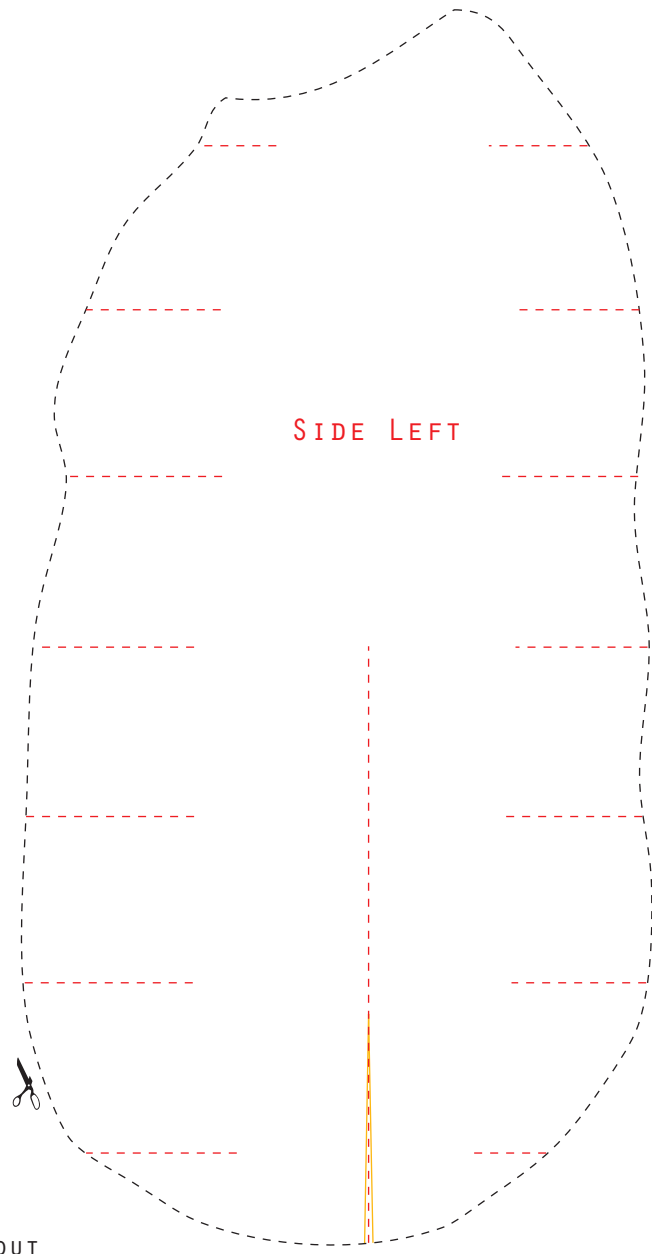
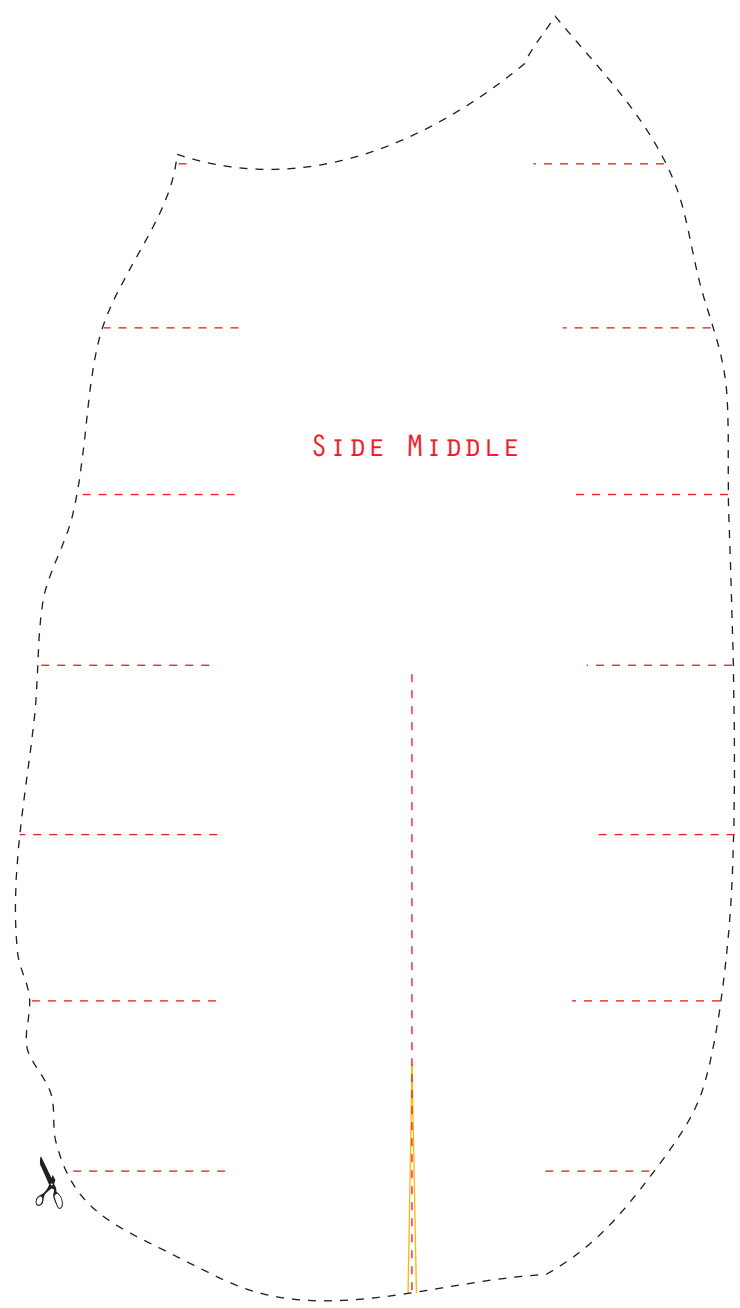
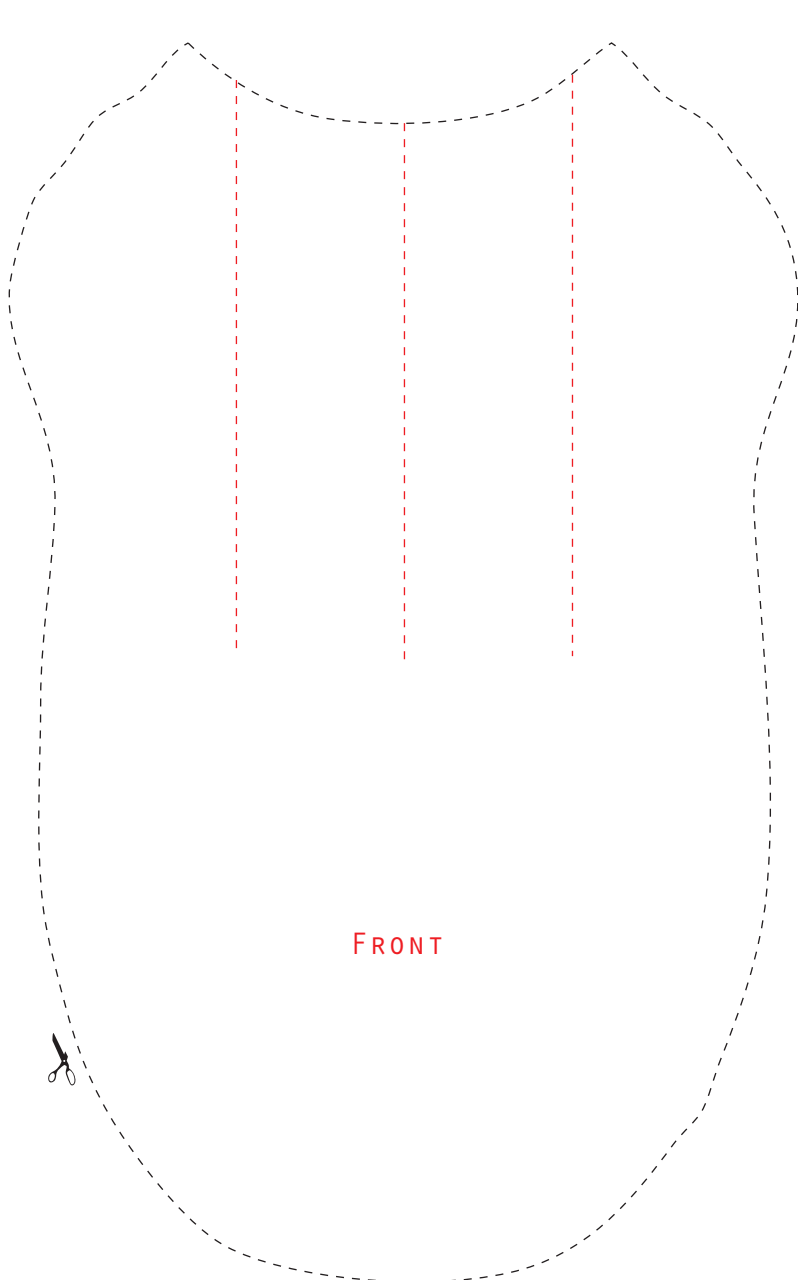

- - - CUT OUT
- - - MAKE INCISION
- WIDEN IF NESCECARY





TORSO

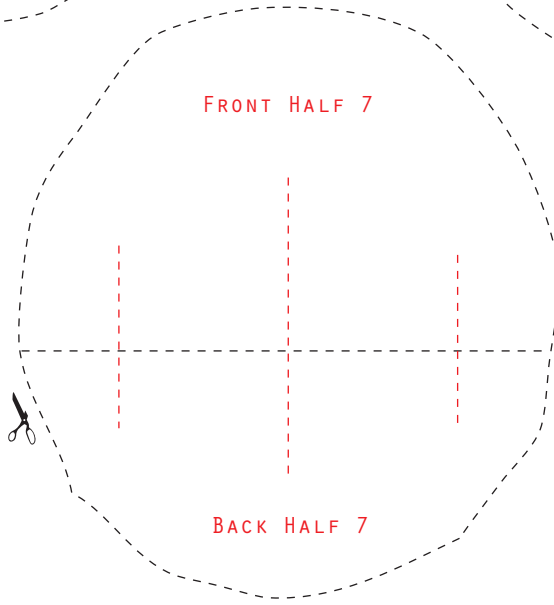
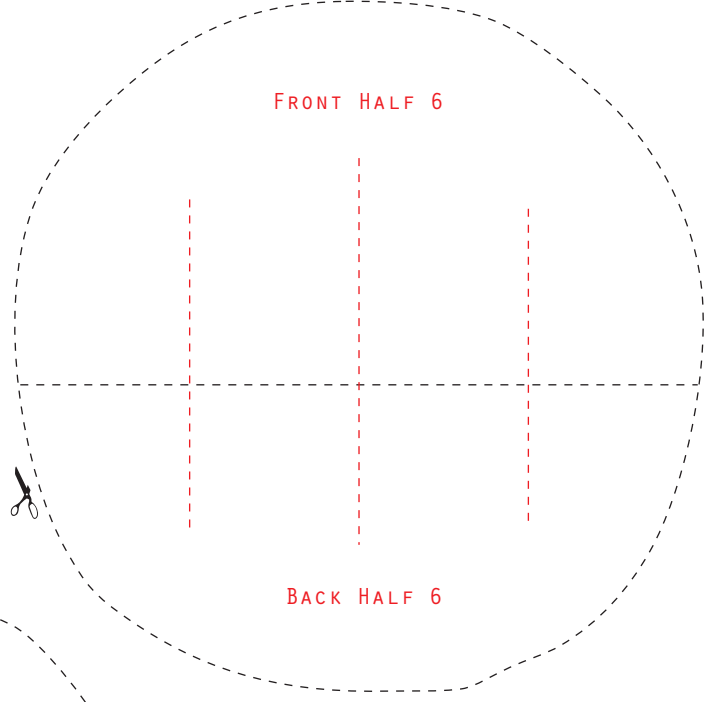
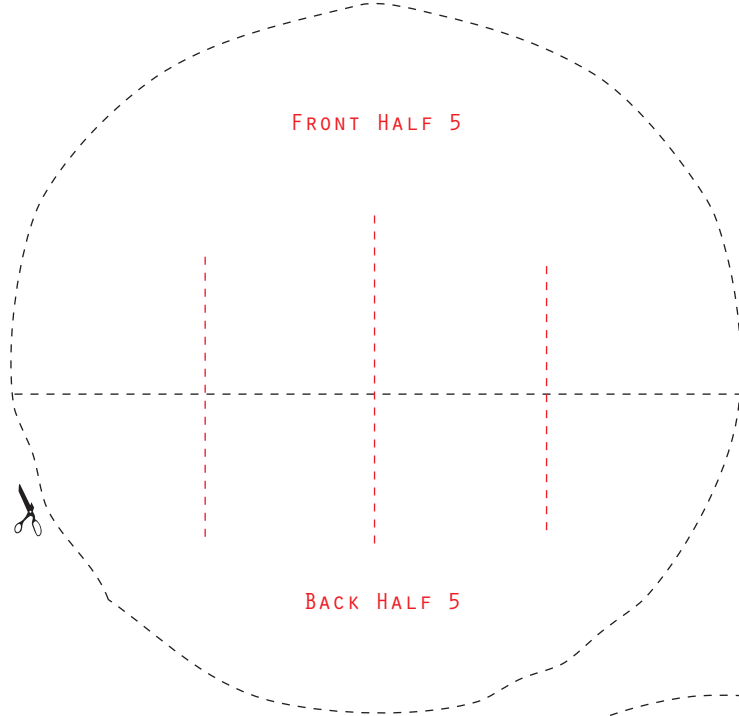
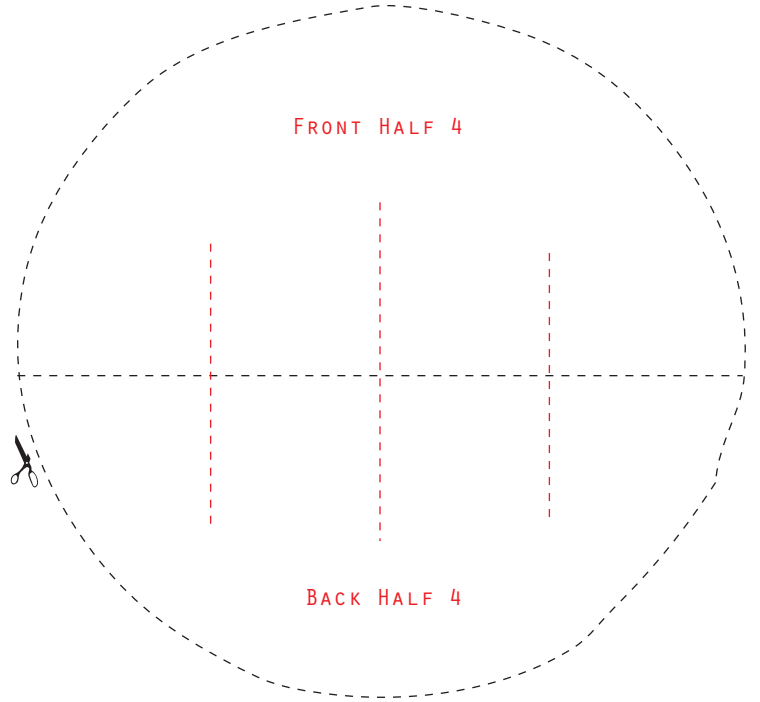
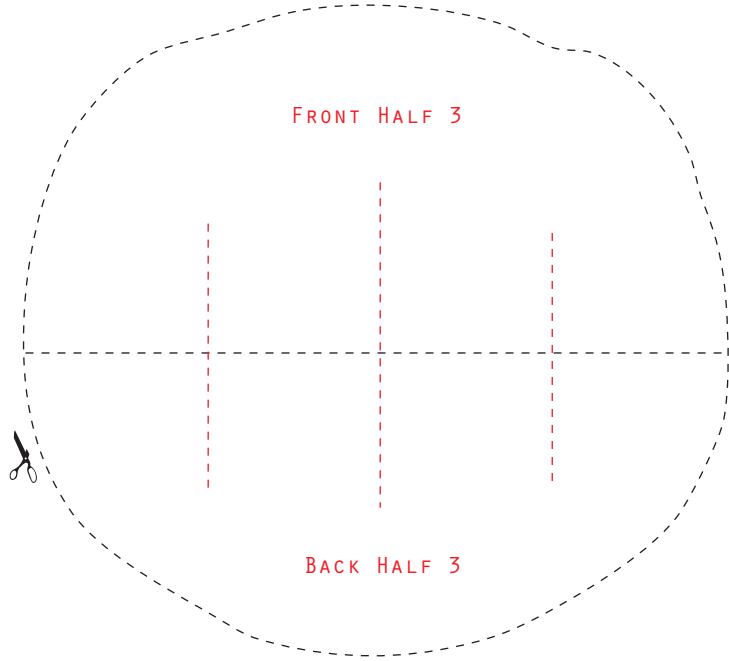
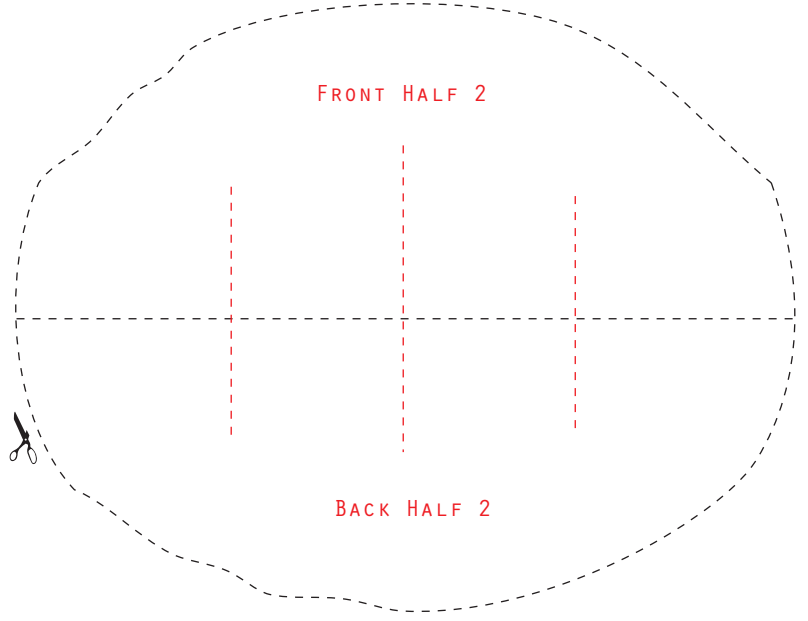
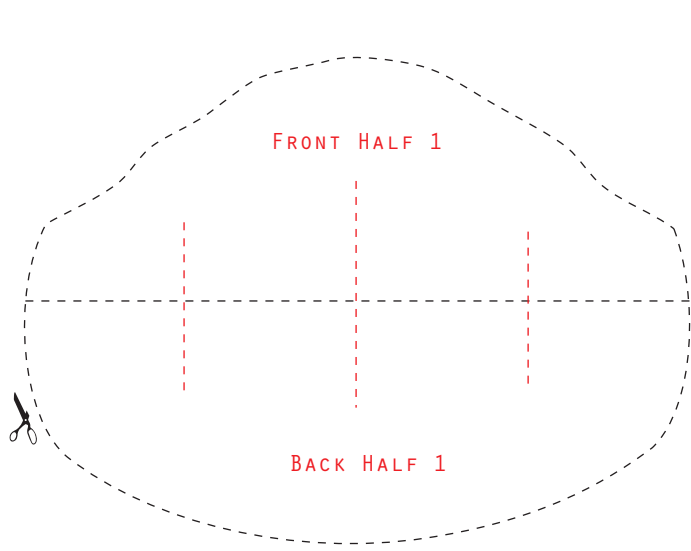

- CUT OUT
- - - MAKE INCISION
- WIDEN IF NESCECARY

TORSO ASSEMBLED

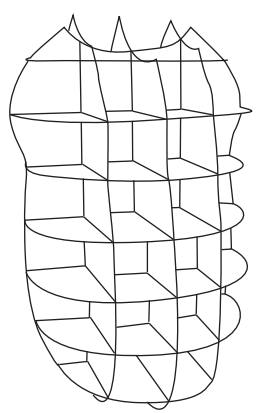

# ARMS

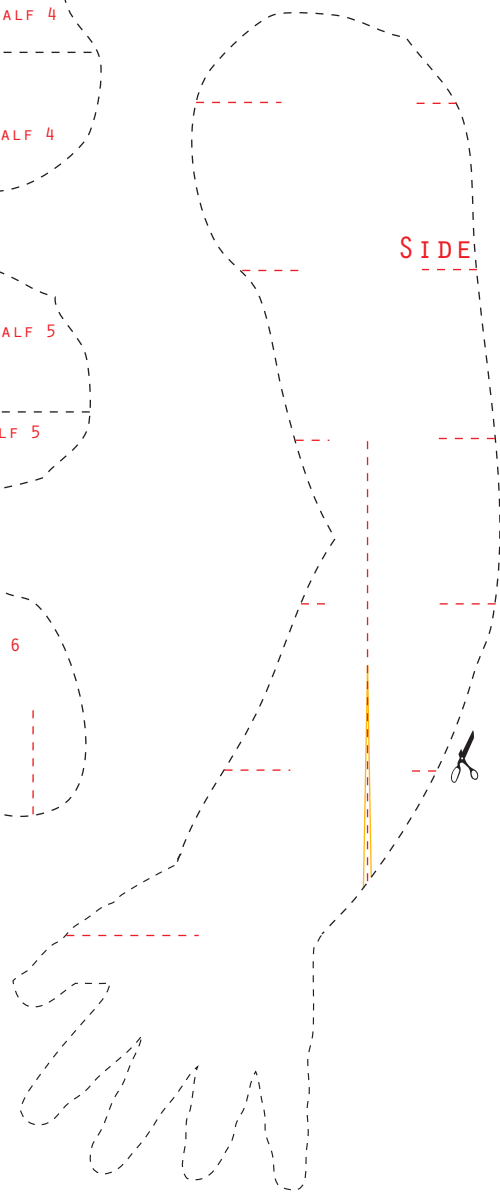
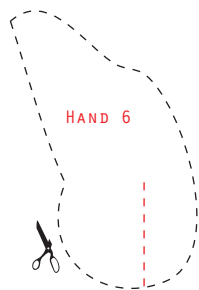
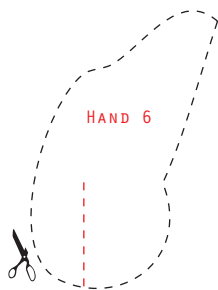
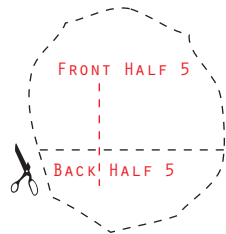
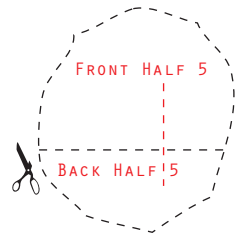
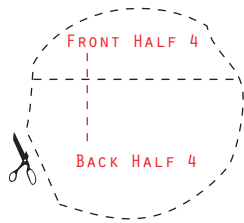
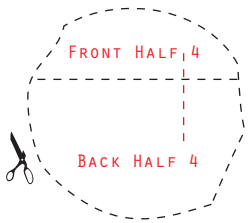
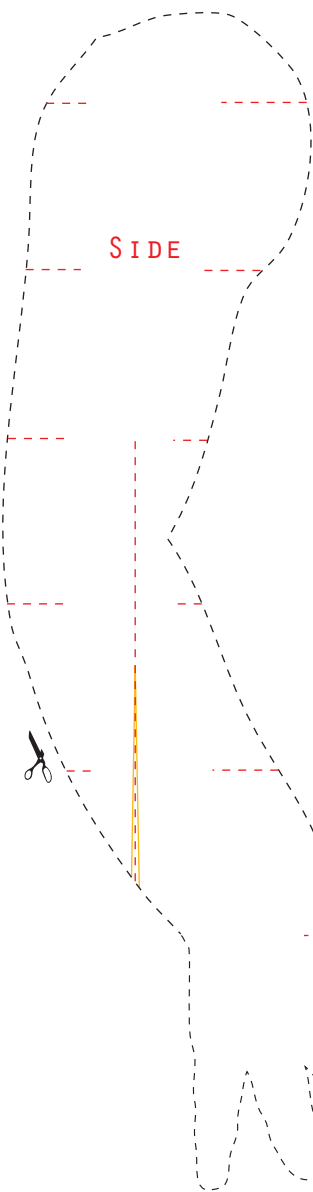
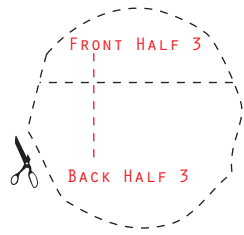
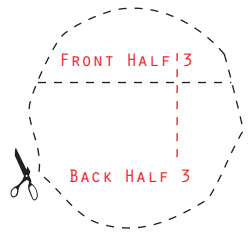
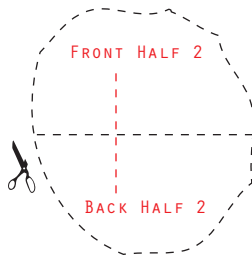
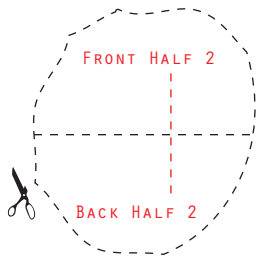
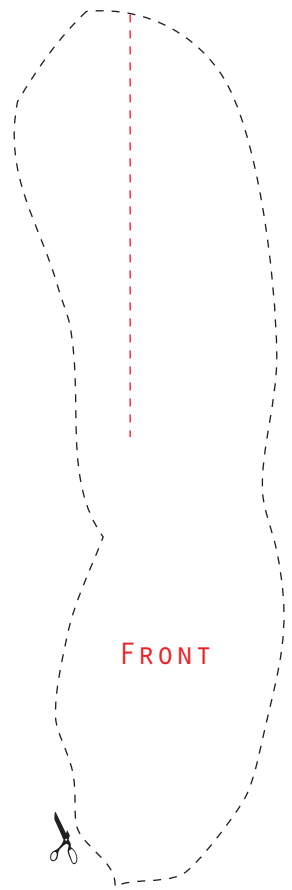
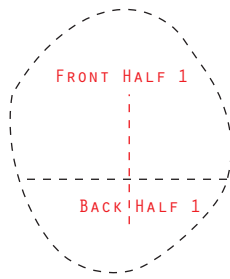
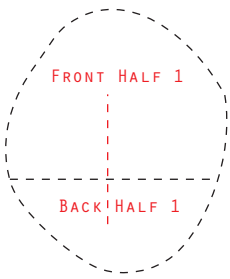
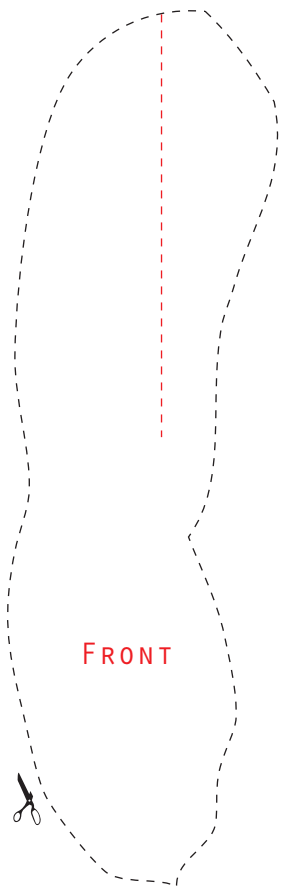

ARM ASSEMBLED

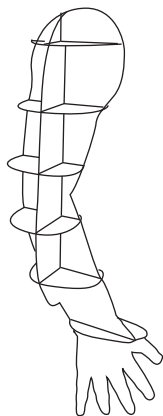

- CUT OUT
- - - MAKE INCISION
- WIDEN IF NESCECARY



# PELVIS

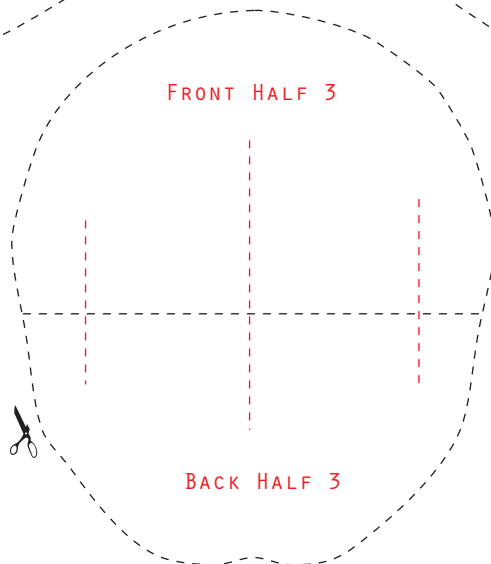
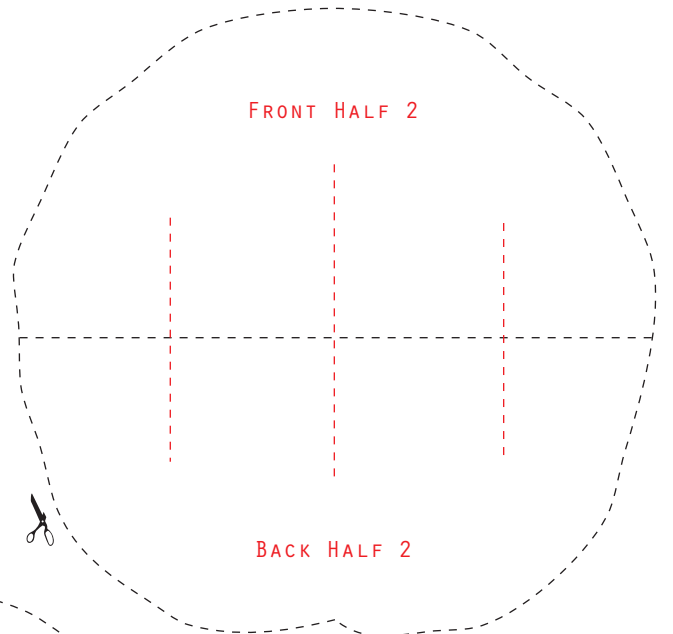
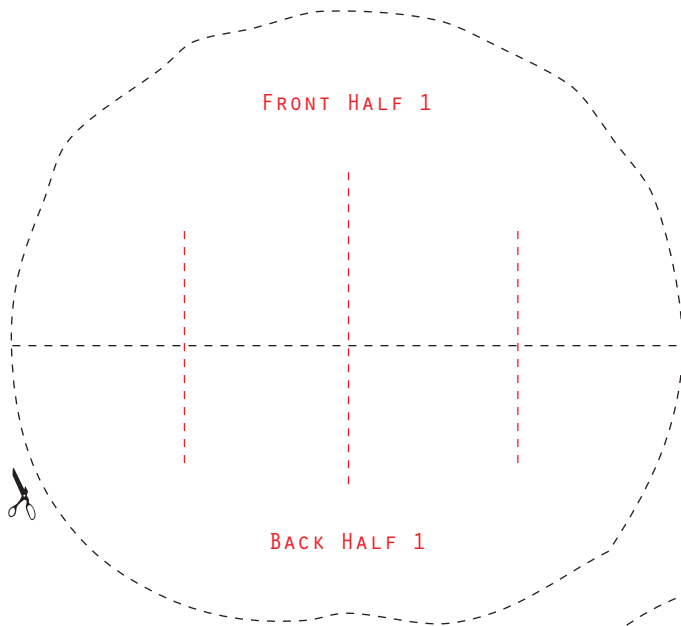
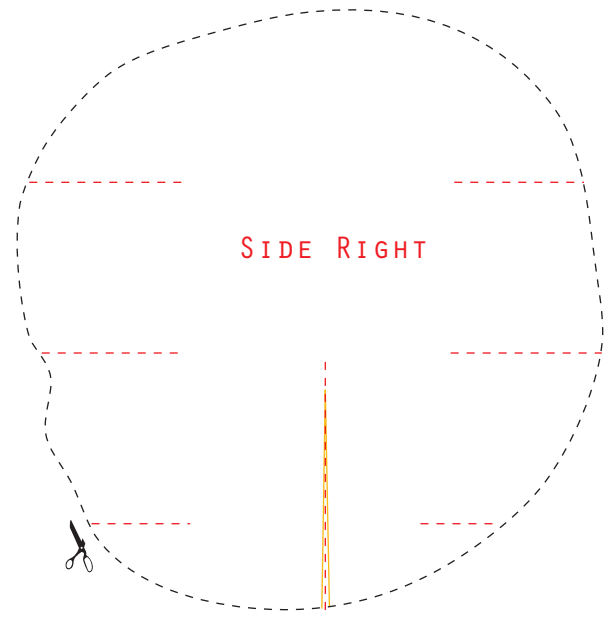
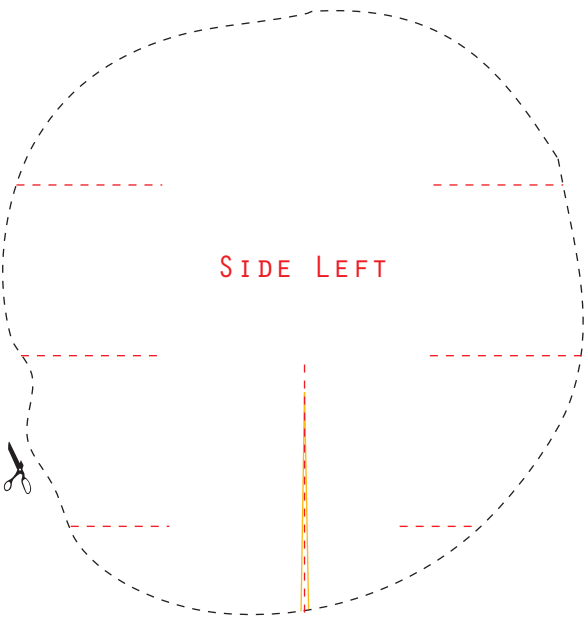
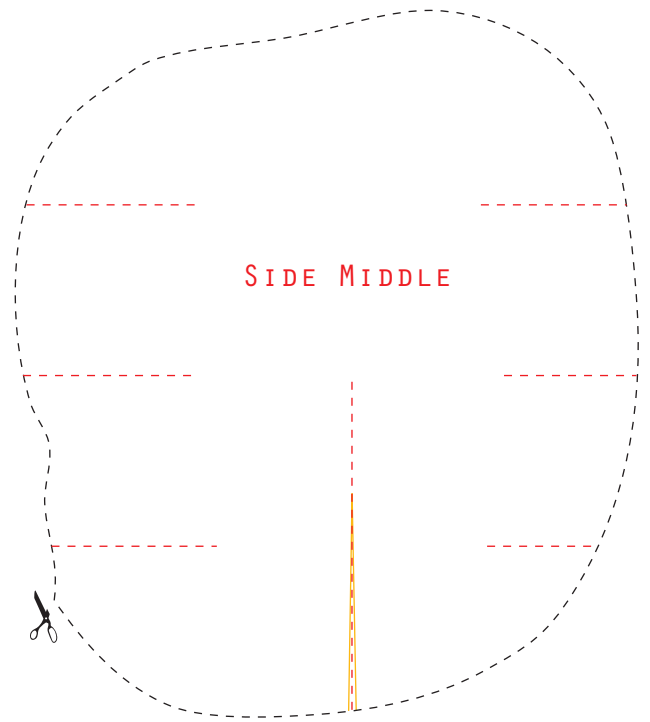
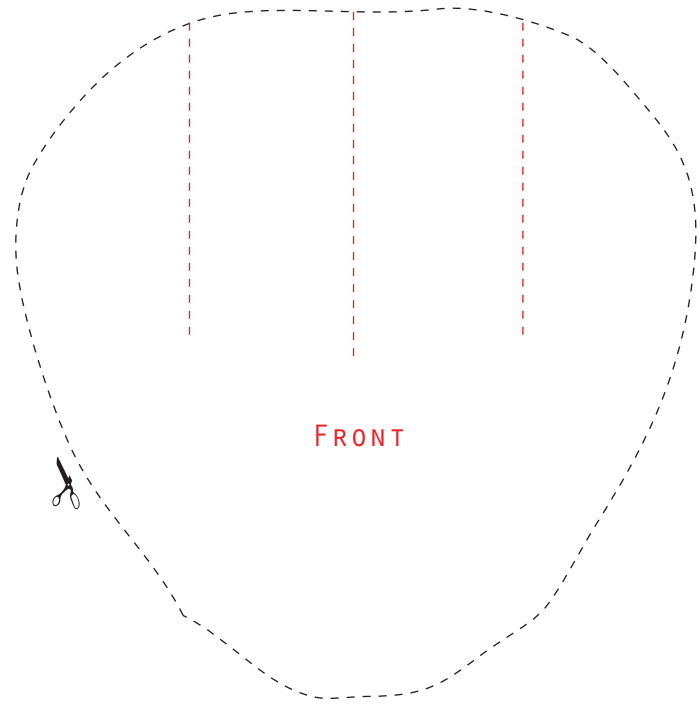

- CUT OUT
- - - MAKE INCISION
- WIDEN IF NESCECARY

PELVIS ASSEMBLED

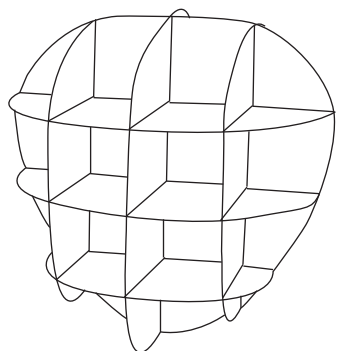

# LEGS

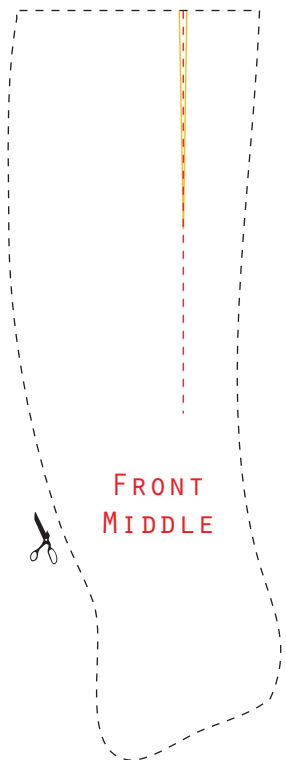
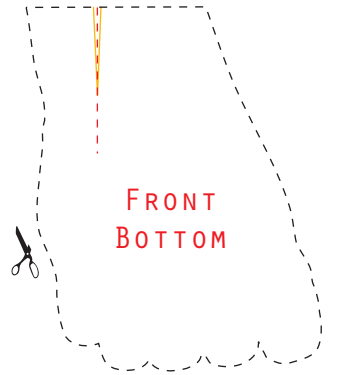
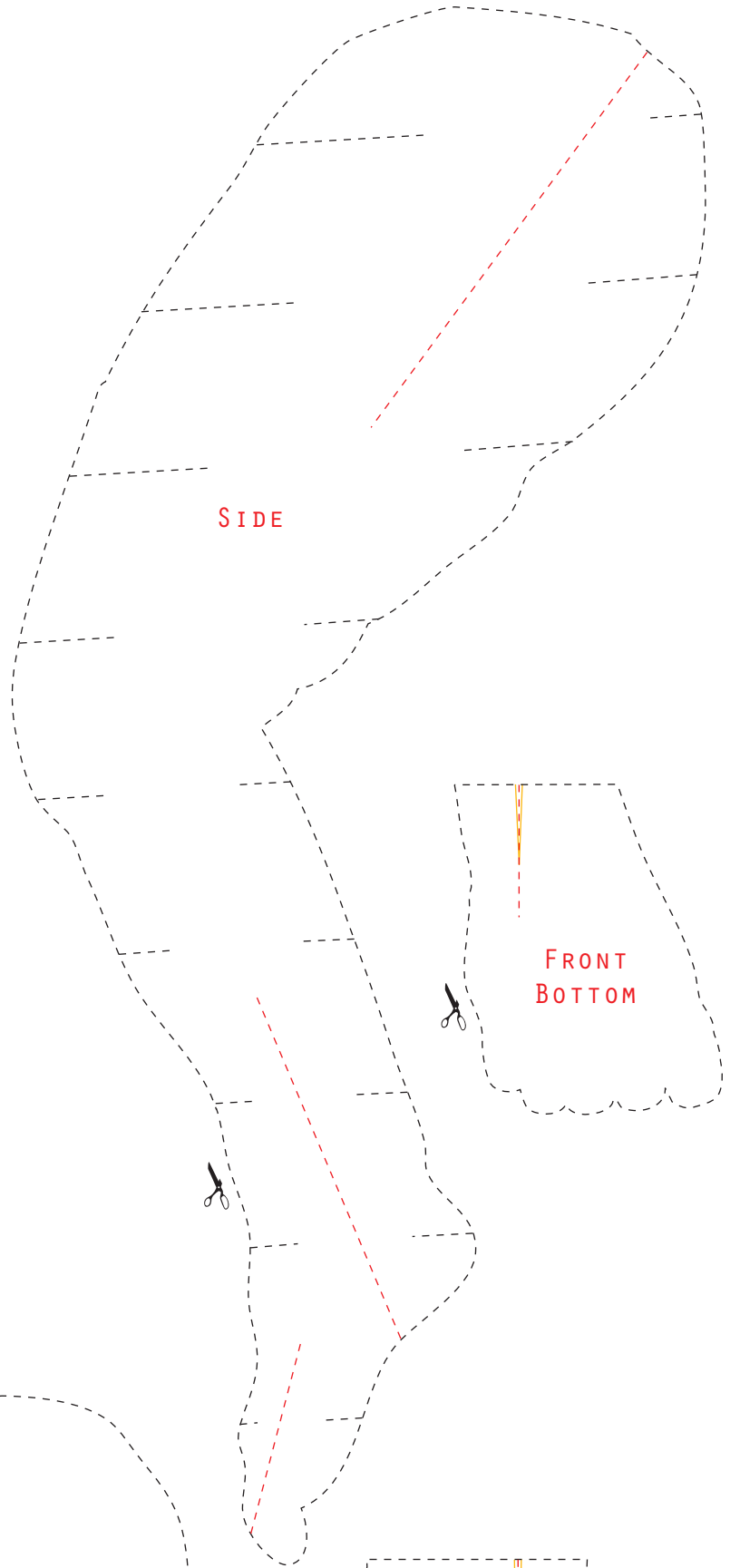
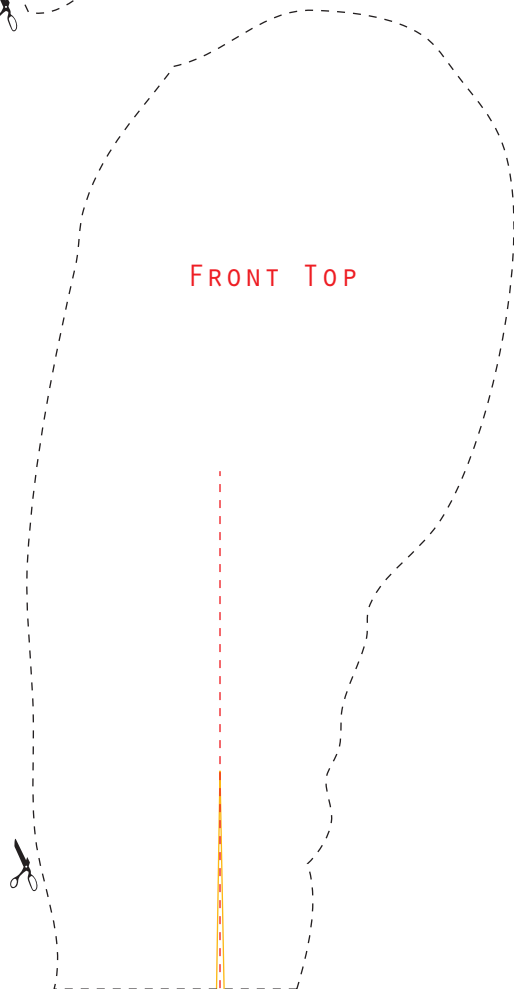
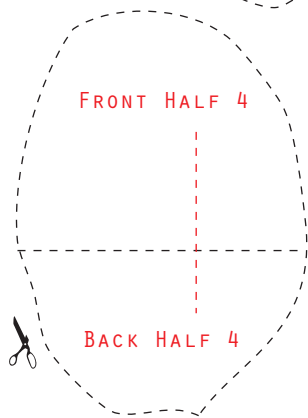
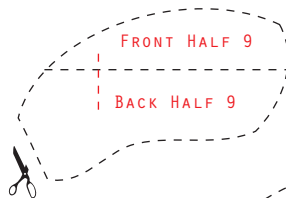
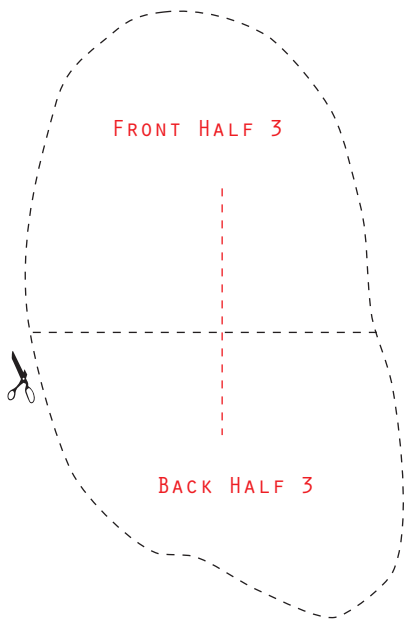
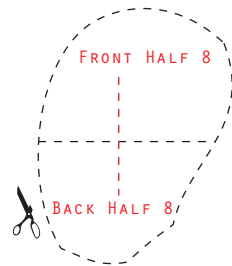
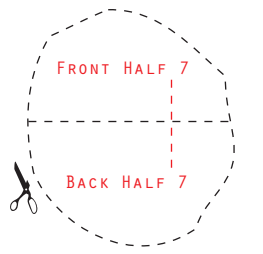
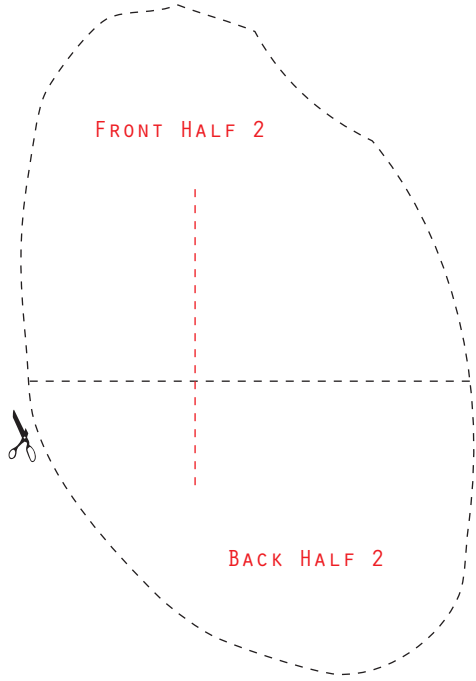
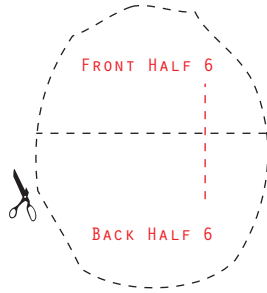
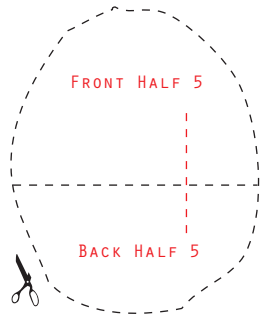
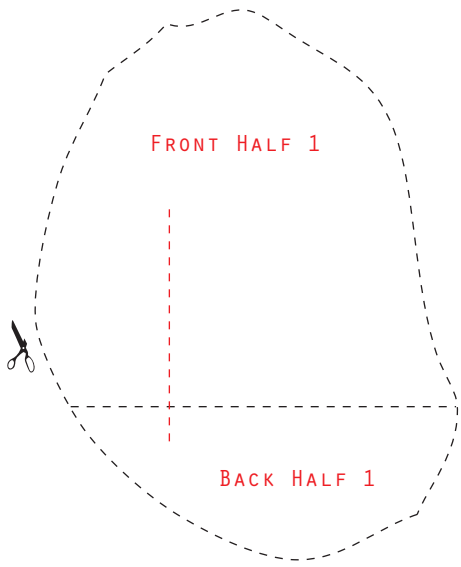

- CUT OUT
- - - MAKE INCISION
- WIDEN IF NESCECARY



# LEGS

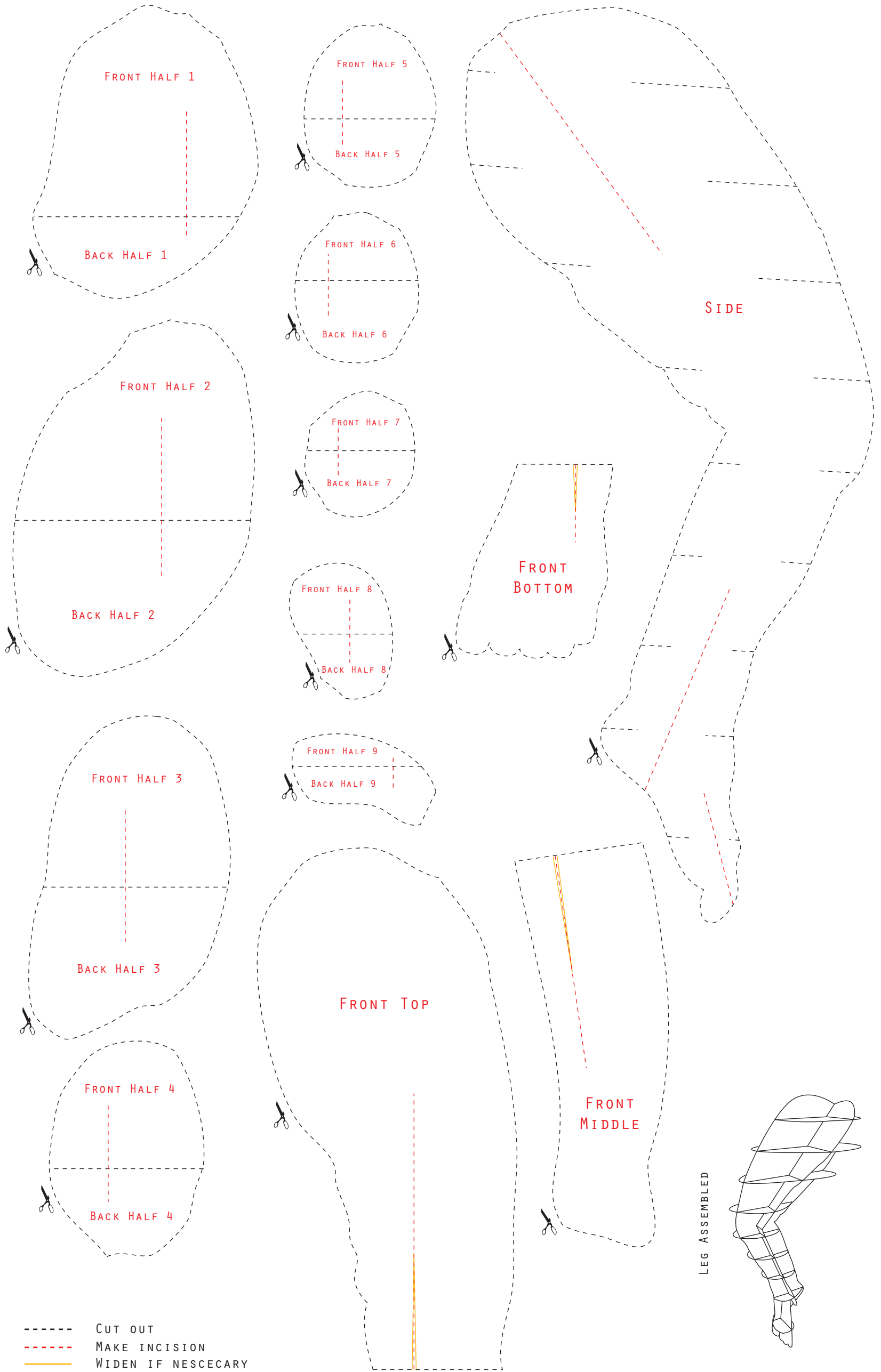

New  
with after birth  
"changeable gender"  
option

# Now SEXUALLY TRANSMITTED CHILDREN

*by Call Me Frank*

TIRED OF SEEING YOUR BUDGET BABY GETTING ALL WORN-OUT AND DISSOLVE IN THE RAIN?

**THEN UPGRADE NOW!**

GO TO [WWW.NONSEXUALLYTRANSMITTEDCHILDREN.COM](http://WWW.NONSEXUALLYTRANSMITTEDCHILDREN.COM)

AND ORDER YOUR PREMIUM BABY,  
THIS BAD BOY/GIRL IS MADE OUT OF 100% PLASTIC AND WILL LAST A LIFE TIME!



NON-STC PREMIUM BABY  
42,5cm/61,5cm/8,5cm  
PREMIUM BABY INSTALLATION  
171cm/63cm/15cm





DOES THE PREMIUM BABY JUST NOT REFLECT YOUR SOCIAL POSITION AND LIFE STYLE  
CLEAR ENOUGH IN FRONT OF YOUR FRIENDS AND ACQUAINTANCES?

*THEN UPGRADE NOW!*

GO TO [WWW.NONSEXUALLYTRANSMITTEDCHILDREN.COM](http://WWW.NONSEXUALLYTRANSMITTEDCHILDREN.COM)

AND ORDER YOUR PLATINUM BABY,  
THE ULTIMATE ACCESSORY FOR EVERY SELF-CONSCIOUS MODERN WOMAN AND MAN.



"NON-STC PLATINUM BABY INSTALLATION VIEW"

AVOID STC PLATINUM BABY CLOSED  
80cm/50cm/50cm  
AVOID STC PLATINUM BABY OPEN  
160cm/77cm/50cm

PROJECT: NON SEXUALLY TRANSMITTED CHILDREN BY CALL ME FRANK

IN THIS PROJECT ENTITLED "NON SEXUALLY TRANSMITTED CHILDREN" CALL ME FRANK EXPRESSES, IN A HUMOROUS WAY, HOW CHILDREN ARE VIEWED AND USED IN MODERN DAY SOCIETY. CALL ME FRANK EXPLAINS THAT NOWADAYS CHILDREN ARE BROUGHT INTO THIS WORLD FOR VARIOUS KINDS OF REASONS - EXCEPT THE RIGHT ONE - OUT OF LOVE.

NUMEROUS YOUNG WOMEN THAT ESCHEW WORKING SEDUCE YOUNG BOYS TO GET THEM PREGNANT, ONLY FOR ALIMONY REASONS. THEN THERE ARE THE BUSINESSWOMEN WHO NEVER HAD THE TIME TO FIND THE RIGHT PERSON AT THE EXPENSE OF THEIR PROFESSIONAL SUCCESS. THEY JUST WANT THE EXPERIENCE OF A CHILD BEFORE THEY GET TOO OLD FOR IT.

THERE ARE PEOPLE WHO APPEAR IN THE MEDIA FOR VARIOUS KINDS OF REASONS THEY WANT A CHILD FOR FASHIONABLE REASONS.

AND THERE ARE THOSE WHO HAVE A CHILD TO ASSIST THEM BEGGING FOR MONEY TO SUPPORT THEIR DRUG ADDICTION, THOSE AIMING RELIGIOUS EXPANSION, AND THE ONES TARGETING GLOBAL DOMINATION. THIS LINE-UP GOES ON AND ON...

DUE TO THESE REASONS IT OFTEN APPEARS THAT "THE CHILD" HAS BECOME A PRODUCT, AND BASED ON THIS AWARENESS CALL ME FRANK CREATED 3 UNIQUE BABIES.

THE BABIES ARE PRESENTED AS A SO CALLED ONLINE ORDER PROCESS WHERE INTERESTED BUYERS CAN GO ANONYMOUS AND ORDER A BABY BASED ON THEIR PROPER NEEDS.

THE BUDGET BABY, MADE OUT OF PAPER IS THE LEAST EXPENSIVE VERSION BUT ALSO THE HARDEST TO ASSEMBLE JUST LIKE IN REAL LIFE, THE LACK OF MONEY MAKES IT HARDER TO MAKE AND ALSO MAINTAIN A CHILD. A RATIONAL OFFER TO GET THE PARENTHOOD-FEELING. THE PREMIUM BABY, MADE OUT OF 100% LONG LASTING POLYAMIDE, IT IS PRESENTED LIKE AN OLD CLICK AND GLUE TOY, AND HAS LOT'S OF EXTRA'S TO SUPPORT YOU TO ASSEMBLE IT. IT IS A FAIR OFFER IN GOOD QUALITY AND VALUE FOR MONEY DEAL.

THE LUXURY BABY, MADE OUT OF CERAMIC, IT REPRESENTS THE FRAGILITY OF A CHILD IN ORDER TO GET THE FULL EXPERIENCE. IT COMES WITH A DETAILED INSTRUCTION MANUAL SEVERAL AEROSOL PAINTS AND GLUE, EYE COLOUR AND GENDER STICKER SHEETS. THE CRATE IT COMES IN IS ALSO A WORKING BENCH TO HELP MAKE THE ASSEMBLING AS EASY AND SMOOTH AS POSSIBLE. IT'S THE TOP OF THE RANGE AN LEAVES NO OPTIONS OPEN.

SPECIAL THANKS,

LUC DE GROOF - **die kunstgalerie** & SIAMAK BAGHERZADEH - TANMEDIA (FOR TECHNICAL SUPPORT)

MELANIE NEVILLE & MY MOM (FOR BELIEVING IN ME)

AND THE ANNOYING PEOPLE IN THE WORLD (FOR GIVING ME THE IDEA).